

AS 32 – 4Z

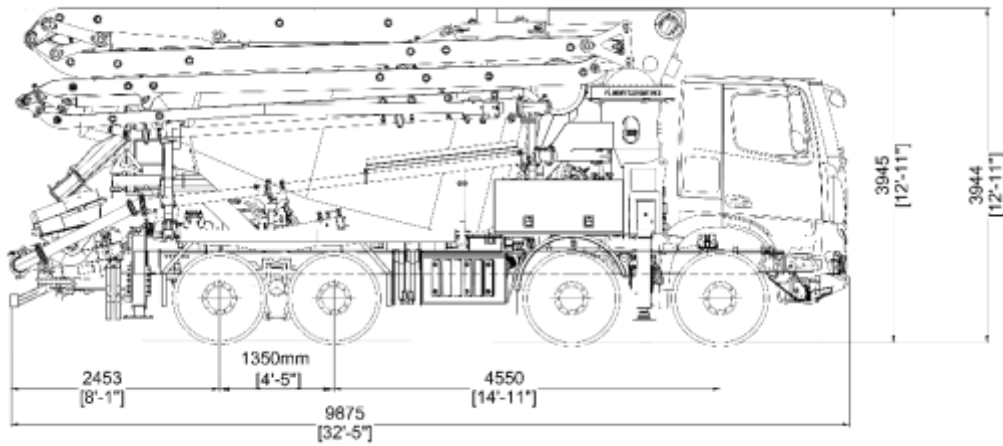

Note : Dimensions may vary depending on truck model.

Pump Group	AS 32.70 4Z
Theo. Conc. Output (max) (Piston Side)	70 m ³ / h (91,55 yd ³ / h)
Theo. Conc. Pressure (max) (Piston Side)	81 bar (1147,80 psi)
Stroke	28 Stroke / min
Concrete Cylinder Dimensions	230 mm x 1000 mm (9,05" x 39,37")

Standard Equipment	
Hopper Capacity	: 450 l (118,87 gal)
Switching System	: Elect. Magn. Sensor
Concrete Valve	: S Valve System
Electric Box	: Waterproof and PLC Controlled
Remote Control	: Included (HETRONIC)
End Hose	: 3 m (9'10")
Water Tank Capacity (Tank)	: 500 l (132,08 gal) and Hose 15 m (49' 2") (Pressure Tank)
Lubrication System	: Hydraulic (LINCOLN)
Driven by	: Gear Box

Boom System	
Boom Type	: 4Z
Sections	: 4
Boom Swing Speed	: 116 sec
Boom Swinging Angle	: 365°
Concrete Pipe Diameter	: 100 mm (4")

Support Legs System	
Front Legs	: X
Rear Legs	: Fixed

Mixer System	
Nominal Capacity	: 9 m ³ (11,77 yd ³)
Drum Speed	: 1-13 rpm
Filling Ratio	: 73%

Control System	
■ Smartstar Control	
■ Color LCD	
■ Rear Keyboard	
■ Diagnostic	
■ Fuel Saving Mode	

Options	
■ Hopper Vibrator	
■ Hydraulic Driven Fan	
■ Stability Control	
■ Air Compressor	
■ End Hose Squeeze Valve	
■ High Pressure Cleaning Kit (135 bar / 1958 psi)	
■ Betonstar IoT System	
■ Remote Control (HBC)	
■ Auto Unfolding	
■ Water and Oil Tank Heater	
■ Water Pump Hydraulic Operated	

Boom Working Diagram

