

**BSS 36**

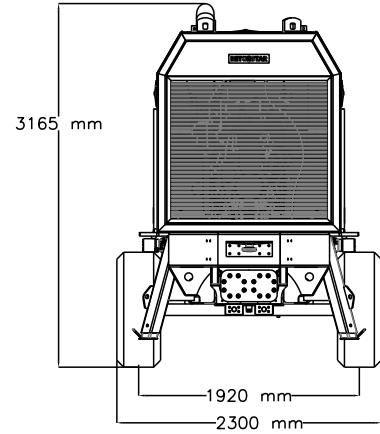
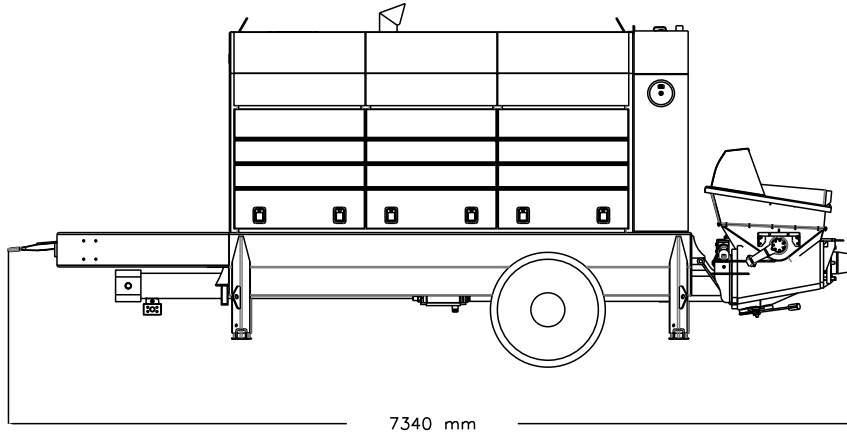

**GENERAL**

Weight : 10.500 kg

**ENGINE\***

Power : 515 kW (700 hp) (Diesel)

**PUMPING UNIT**

Rod Side	Theo. Conc. Output (max)	: 103 m <sup>3</sup> /h
	Theo. Conc. Pressure (max)	: 153 bar
	Stroke	: 27 Stroke / min
Piston Side	Theo. Conc. Output (max)	: 74 m <sup>3</sup> /h
	Theo. Conc. Pressure (max)	: 224 bar
	Stroke	: 19 Stroke / min
Concrete Valve	: S Valve System	
Switch-Over Pressure S-Tube	: 190 bar	
Delivery Cylinders Diameter	: 200 mm	
Delivery Cylinders Length	: 2100 mm	
Hopper Capacity	: 650 l	
Hopper Outlet Diameter	: 125 mm	
Reducer Output Diameter	: 150 mm	
Switching System	: Elect. Magn. Sensor	
Lubrication System	: Hydraulic (LINCOLN)	
Electric Box	: Waterproof and PLC Controlled	

**CONTROL SYSTEM**

- Smartstar Control
- Color LCD
- Diagnostic
- Fuel Saving Mode
- Remote Control

**OPTIONS**

- Hopper Vibrator
- Hydraulic Driven Fan
- Betonstar IoT System
- Remote Control (HBC)
- Air Compressor
- High Pressure Cleaning Kit (140 bar )
- Water Pump (67 lpm)
- Water Tank (500 l and Hose 15 m)

(\* ) Engine power and norm values vary according to the engine brand.