

**BST 52 – 6RZ**

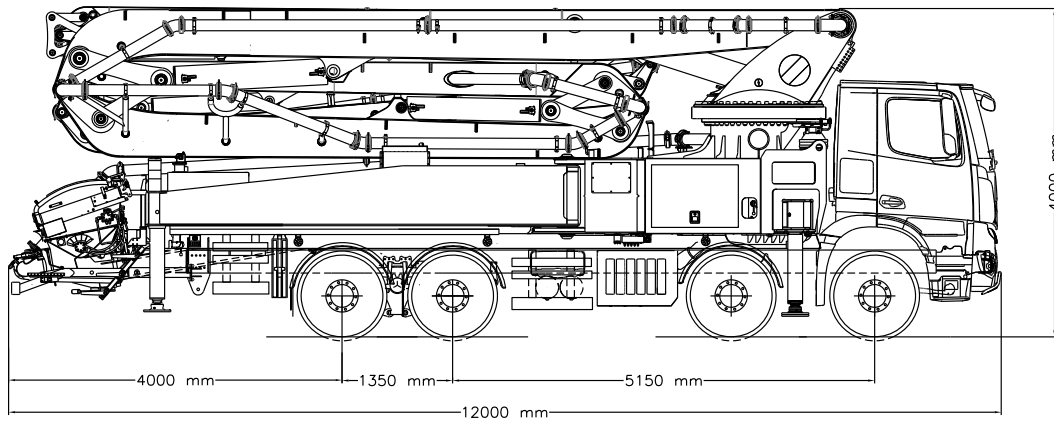

Note : Standard pump model is BST 52.14H 6RZ.

Dimensions may vary depending on truck model.

	BST 52.14H 6RZ	BST 52.16 6RZ
<b>PUMP GROUP</b>	Standard	Optional
Theo. Conc. Output (max) (Piston Side)	140 m <sup>3</sup> /h	160 m <sup>3</sup> /h
Theo. Conc. Pressure (max) (Piston Side)	81 bar	81 bar
Stroke	26 Stroke / min	26 Stroke / min
Concrete Cylinder Dimensions	230 mm x 2100 mm	250 mm x 2100 mm
<b>STANDARD EQUIPMENT</b>		
Hopper Capacity	: 650 l	
Switching System	: Elect. Magn. Sensor	
Concrete Valve	: S Valve System	
Electric Box	: Waterproof and PLC Controlled	
Remote Control	: Included (HETRONIC)	
End Hose	: 3 m	
Water Pump	: 67 lpm	
Water Tank Capacity	: 650 l and Hose 15 m	
Lubrication System	: Hydraulic (LINCOLN)	
Driven by	: PTO or Gear Box	
<b>BOOM SYSTEM</b>		
Boom Type	: 6RZ	
Sections	: 6	
Boom Swing Time	: 204 sec	
Boom Swinging Angle	: 365°	
Concrete Pipe Diameter	: 125 mm	
<b>SUPPORT LEGS SYSTEM</b>		
Front Legs	: X	
Rear Legs	: Side Hydraulic Swing	
<b>CONTROL SYSTEM</b>		
■ Smartstar Control		
■ Color LCD		
■ Rear Keyboard		
■ Diagnostic		
■ Fuel Saving Mode		
<b>OPTIONS</b>		
■ Hopper Vibrator		
■ Hydraulic Driven Fan		
■ Stability Control		
■ Air Compressor		
■ End Hose Squeeze Valve		
■ High Pressure Cleaning Kit (140 bar)		
■ Betonstar IoT System		
■ Remote Control (HBC)		
■ Auto Unfolding		
■ Water and Oil Tank Heater		

**BOOM WORKING DIAGRAM**

