

BSS 21.90E

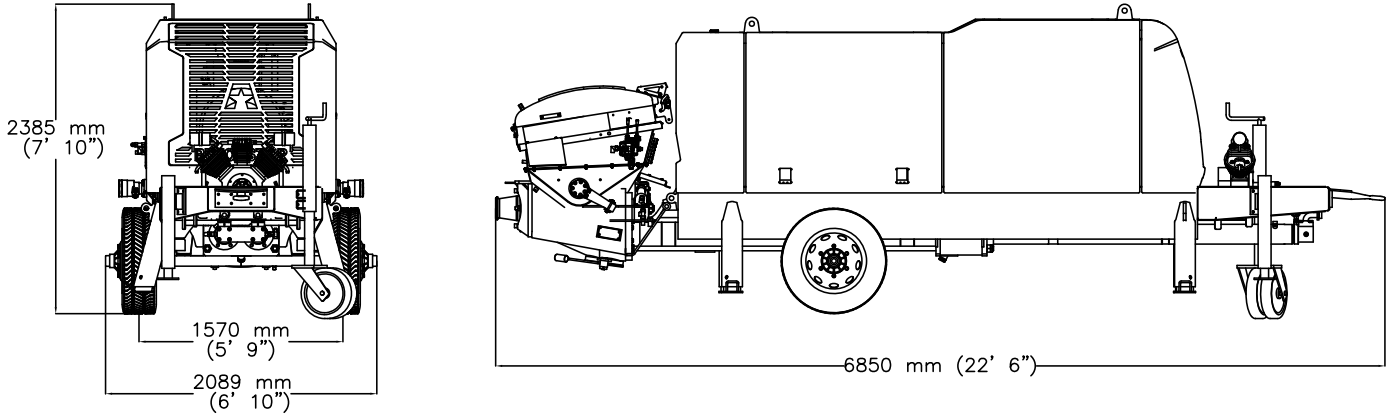

General

Weight : 8.750 kg (19.290 lbs)

Engine*

Power : 160 kW (290 hp)(Electric)

Pumping Unit

Rod side	Theo. Conc. Output(max)	: 90 m ³ /h (117,71 y ³ /h)
	Theo. Conc. Pressure(max)	: 92 bar (1334,34 psi)
	Stroke	: 23 Stroke / min
Piston side	Theo. Conc. Output(max)	: 56 m ³ /h (73,24 y ³ /h)
	Theo. Conc. Pressure(max)	: 150 bar (2175,57 psi)
	Stroke	: 14 Stroke / min

Concrete Valve	: S valve system
Switch-over pressure S-tube	: 190 bar (2755,72 psi)
Delivery cylinders diameter	: 200 mm (7,87")
Delivery cylinders stroke	: 2100 mm (82,68")
Hopper capacity	: 650 lt (171,71 gal)
Hopper outlet diameter	: 125 mm (5,5')
Hopper height	: from the ground 1460 mm (57,48")
Lateral output pipeline	: 150 mm (6')
Maximun outlet agitator	: 32,9 rpm
Switching System	: Elect. Magn. Sensor
Lubrication System	: Hydraulic (LINCOLN)

Hydraulic System

Max. hydraulic pressure : 350 bar (5076,32 psi)

Control

Remote control	: Included
Control	: Smartstar
Color LCD	: Included
Diagnostic	: Included
Fuel saving mode	: Included
Electric box	: Waterproof and PLC controlled

Options

■ Air compressor	Hydraulic motor driven	: 5,5 kW
	Working pressure	: 15 bar(217 psi)
	Supplied air flow capacity	: 555 l/min (146.61 gpm)
	Power	: 3 kW
■ Water pump	Water pressure (max.)	: 13 bar (188,55 psi)
	Water flow	: 67 l/min (17,7 gpm)
	Pump speed	: 2900 rpm
	Hydraulic pressure	: 210 bar (3045,8 psi)
■ Water tank	Water hose	: 15 m (49' 2")
	Water tank capacity	: 500 lt (132 gal)
	Material	: Steel
■ High pressure cleaning kit	Power	: 4 kW
	Water pressure	: 150 bar (2175,57 psi)
	Water flow	: 18 l/min (4,75 gpm)
	Hydraulic pressure	: 210 bar (3045,8 psi)
■ Hopper vibrator (Electric)	Hose reel	: Automatic hose reel
■ Hydraulic dirven fan		
■ Betonstar IoT system		

(*) Engine power and norm values vary according to the engine brand.