

BSS 10.70 CP

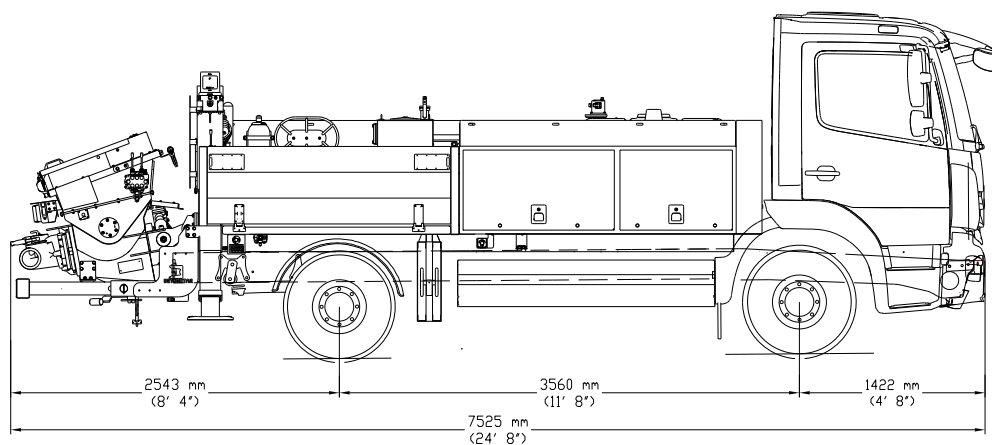

Note : Dimensions may vary depending on truck model.

General

Weight(without truck) : 4645 kg (10240,47 lbs)

Pumping Unit

	Theo. Conc. Output(max)	: 70 m ³ /h (91,55 y ³ / h)
Piston side	Theo. Conc. Pressure(max)	: 80 bar (1174,80 psi)
	Stroke	: 28 Stroke / min
	Theo. Conc. Output(max)	: 90 m ³ /h (117,71 y ³ /h)
Rod side	Theo. Conc. Pressure(max)	: 54 bar (783,20 psi)
	Stroke	: 36 Stroke / min

Concrete Valve	: S valve system
Switch-over pressure S-tube	: 190 bar (2755,72 psi)
Delivery cylinders diameter	: 230 mm (9,05")
Delivery cylinders stroke	: 1000 mm (39,37")
Hopper capacity	: 450 lt (118,88 gal)
Hopper outlet diameter	: 125 mm (5,5')
Hopper height	: from the ground 1460 mm (57,48")
Lateral output pipeline	: 150 mm (6')
Maximun outlet agitator	: 32,9 rpm
Switching System	: Elect. Magn. Sensor
Lubrication System	: Hydraulic (LINCOLN)
Driven by	: PTO or gearbox

Hydraulic System

Max. hydraulic pressure : 350 bar (5076,32 psi)

Control

Remote control	: Included (HETRONIC)
Control	: Smartstar
Color LCD	: Included
Diagnostic	: Included
Fuel saving mode	: Included
Electric box	: Waterproof and PLC controlled

Water Pump

Power	: 3 kW
Water pressure (max.)	: 13 bar (188,55 psi)
Water flow	: Water flow
Pump speed	: 2900 rpm
Hydraulic pressure	: 210 bar (3045,8 psi)
Water hose	: 15m(49' 2")

Water Tank

Water tank capacity	: 650 lt(171 gal)
Material	: Plastic

Options

	Hydraulic motor driven	: 5,5 kW
■ Air Compressor	Working pressure	: 15 bar(217 psi)
	Supplied air flow capacity	: 555 l/min (146.61 gpm)
	Power	: 4 kW
■ High pressure cleaning kit	Water pressure	: 150 bar (2175,57 psi)
	Water flow	: 18 l/min (4,75 gpm)
	Hydraulic pressure	: 210 bar (3045,8 psi)
	Hose reel	: Automatic hose reel
■ Hopper vibrator (Electric)		
■ Hydraulic driven fan		
■ Betonstar IoT system		
■ Remote control(HBC)		