



PUMP GROUP

Pump Group	BST 37.14 5Z
	Standard
"Theoretical Concrete Pumping Capacity Output (max) (Piston Side)"	140 m ³ /h
Theoretical Concrete Pressure (max) (Piston Side)	69 bar
Stroke	26 Stroke/min
Concrete Cylinder Dimensions	230 mm x 2100 mm
Remote Control	Wireless remote control with display
Oil Cooler	Electrical driven / Hydraulic driven

STANDARD EQUIPMENT

Concrete Hopper Volume	650 l
Switching System	Electromagnetic Sensor
Concrete Transfer System	S Valve System
Electric cabinet	IP65 PLC controlled
Remote Control	Two remote (with +without display)
Water Pump	67 l/min
Water tank capacity	650 l
Cleaning Hose	15 m
Hopper system lubrication	Electrically controlled lubrication system
Driven by	PTO or Gearbox

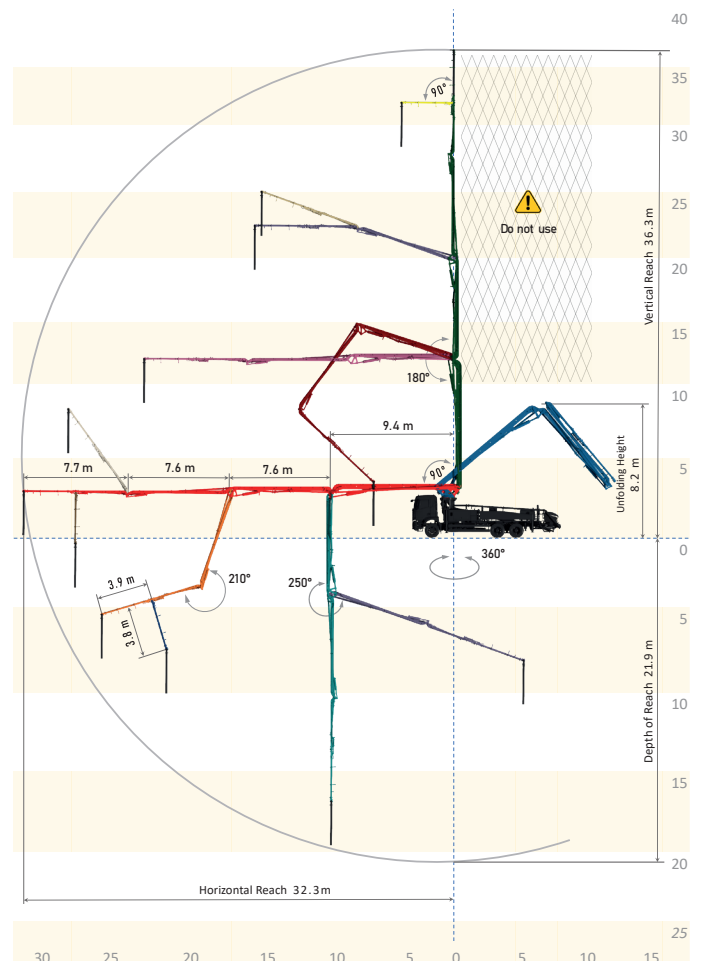

OPTIONS

- Hopper Vibrator
- Stability control
- Air Compressor
- End Hose Concrete Shut-Off Valve
- High Pressure Cleaning Kit
- Automatic Boom Opening (Unfolding)
- Water and Oil Tank Heater
- Hopper Level Sensor

BOOM SYSTEM

Boom type	Z
Sections	5
Boom slewing speed	135 sec
Boom slewing angle	360°
Concrete pipe diameter	125 mm (DN 125)
Vertical reach height	36.3 m
Horizontal reach distance	32.3 m
Unfolding height	8.2 m
Downward reach depth	21.9 m
End hose length	3 m

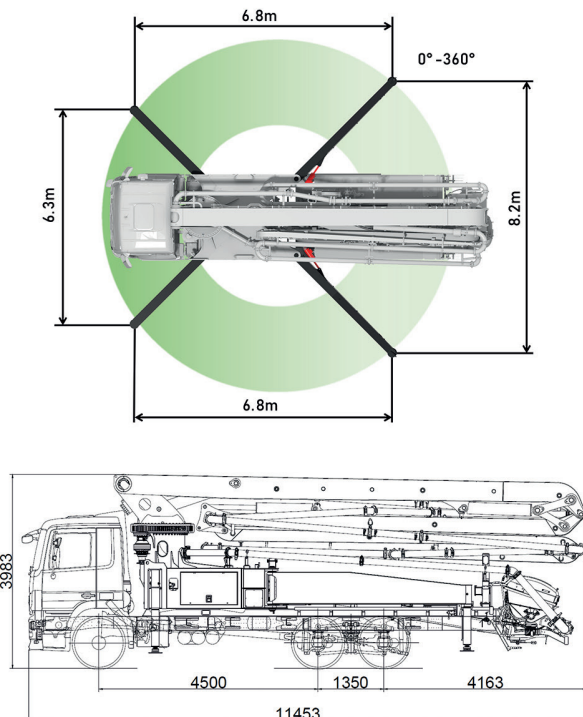

CONTROL SYSTEM

- SmartStar Control
- 7" Color SmartStar Display
- IP69K Electronic Keypad
- Fault Diagnosis
- Fuel Saving Mode
- Proximity Switch Breakdown Mode
- Automatic Power Regulation
- Agitator Rotation Automatic
- Agitator Safety Switch

OUTRIGGER SYSTEM

Front outriggers	X-Type
Rear outriggers	Fixed (Hydraulically Swing)

OPERATING CONDITIONS

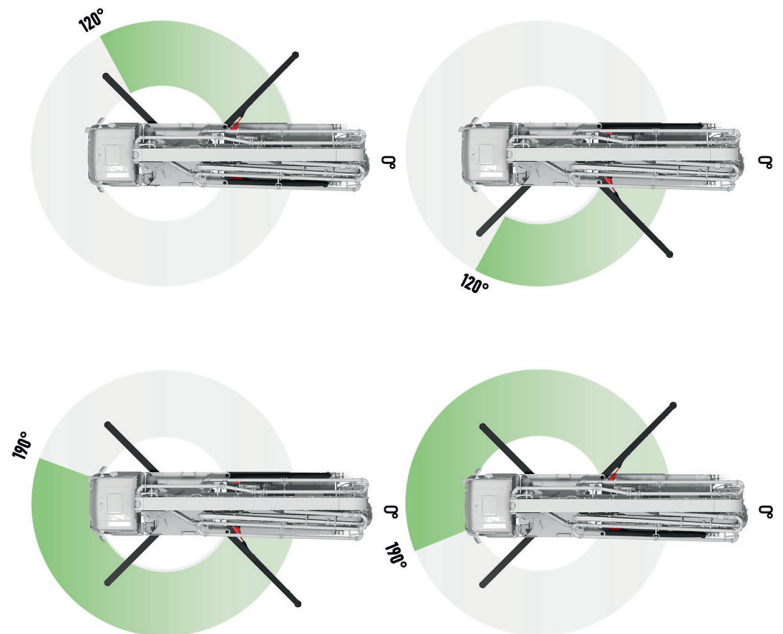

(*) All data shown is theoretical and subject to change without notice.